

Differenzierung „hell – vs. „dunkel – klingend“

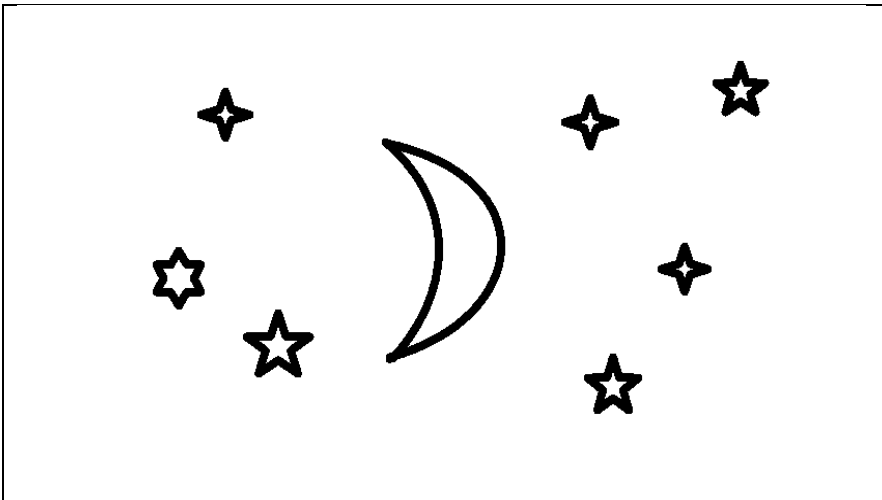

(c) Copyright Schulz-Kirchner-Verlag, Idstein

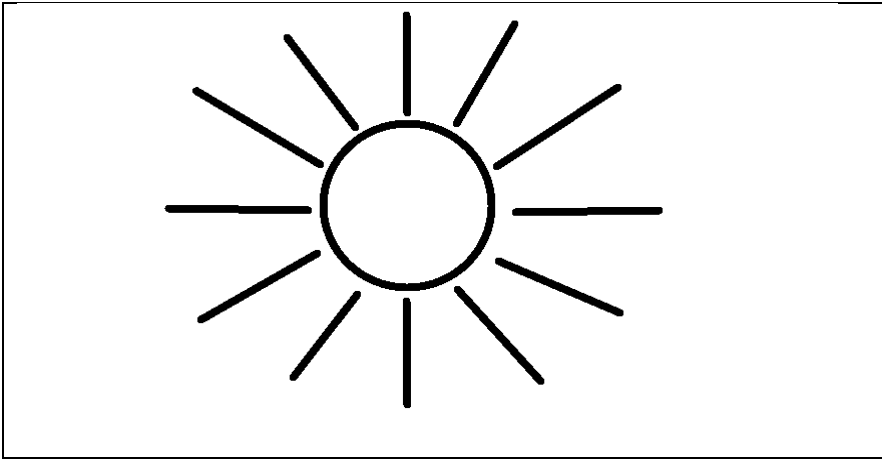
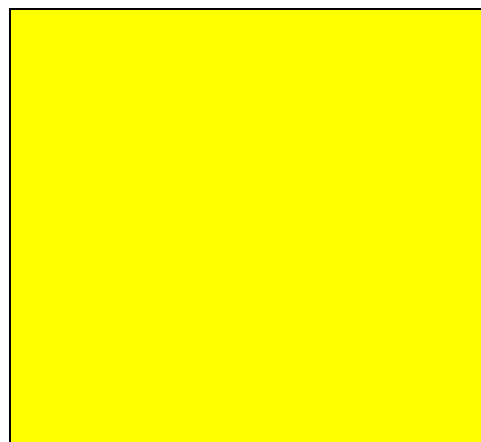

Zungenbilder zur Differenzierung „anterior – posterior“

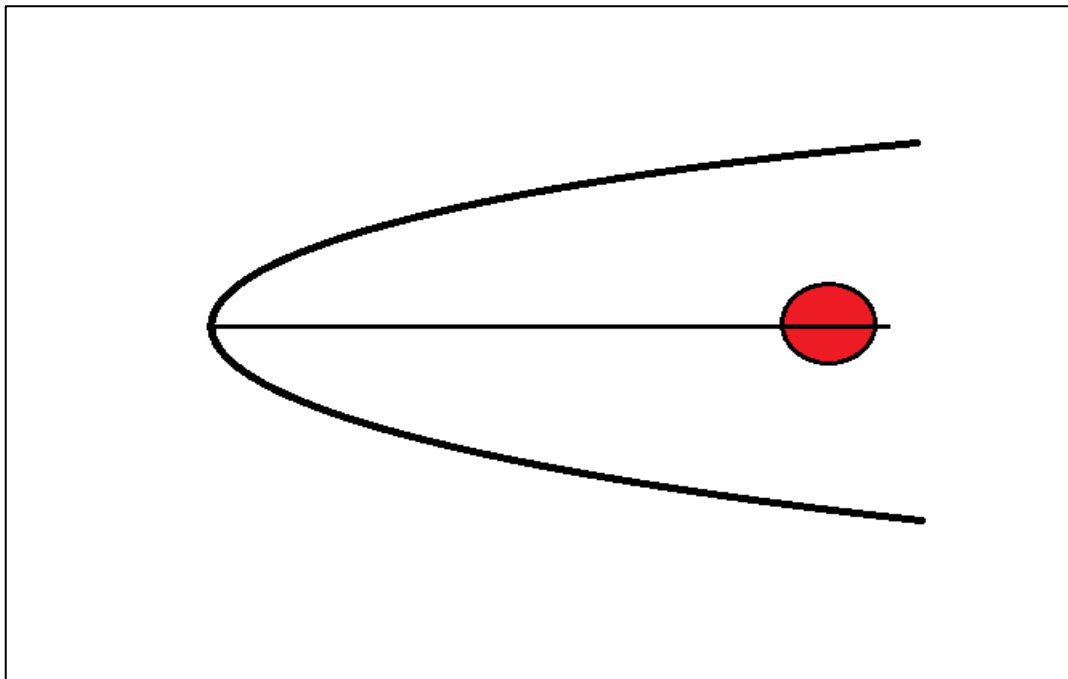
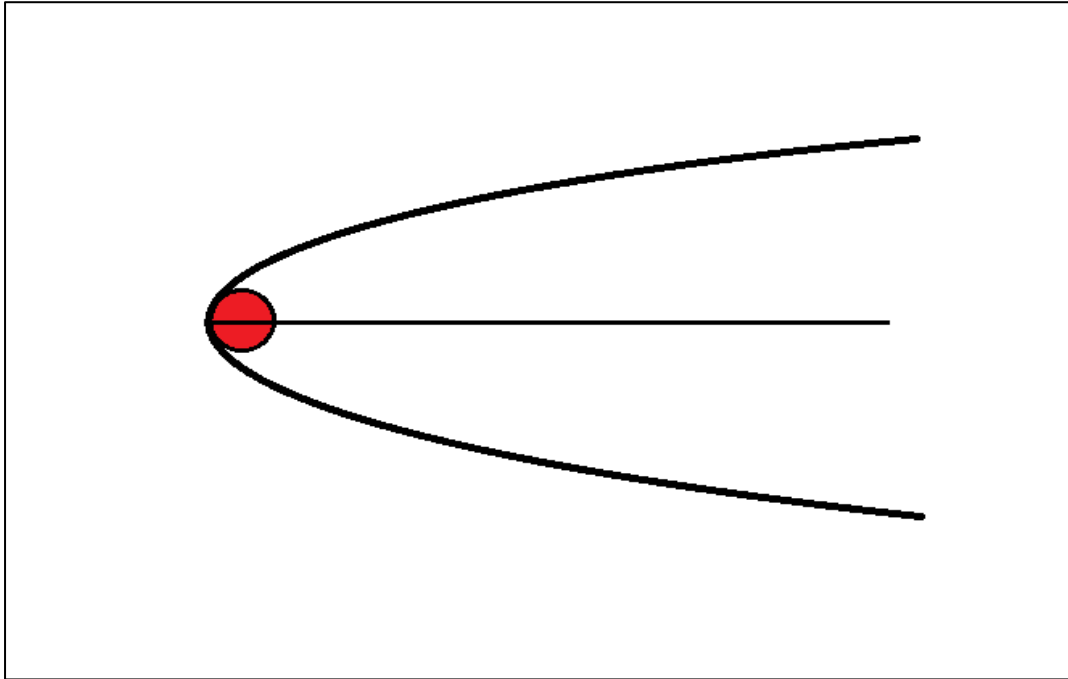

(c) Copyright Schulz-Kirchner Verlag, Idstein

Minimalpaarbilder /t/ - /k/

Tanne

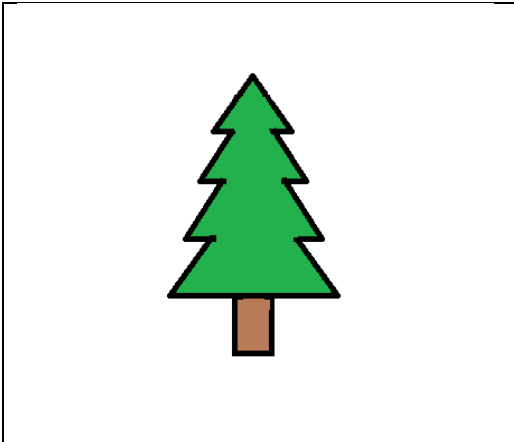

Kanne



Tasse

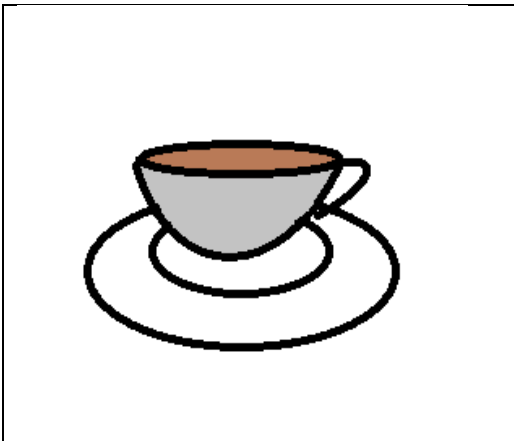

Kasse

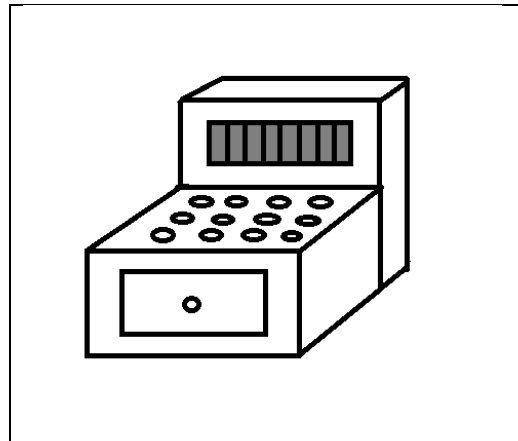

Topf

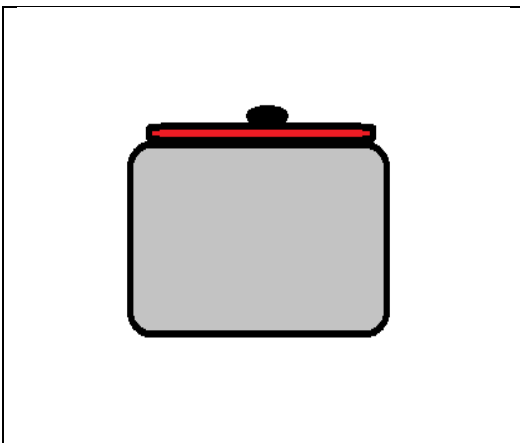

Kopf

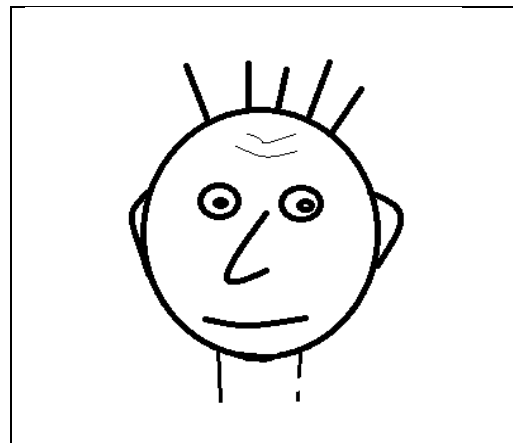

(c) Copyright Schulz-Kirchner Verlag, Idstein

Teller

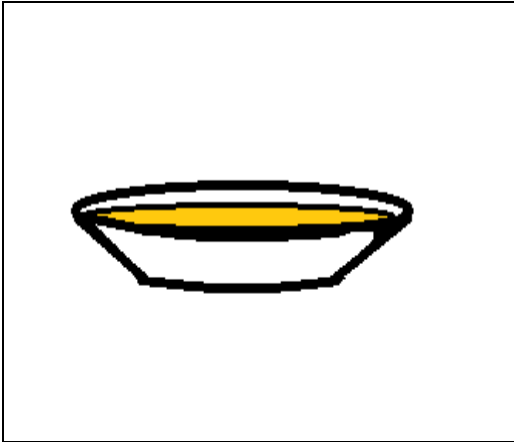

Keller

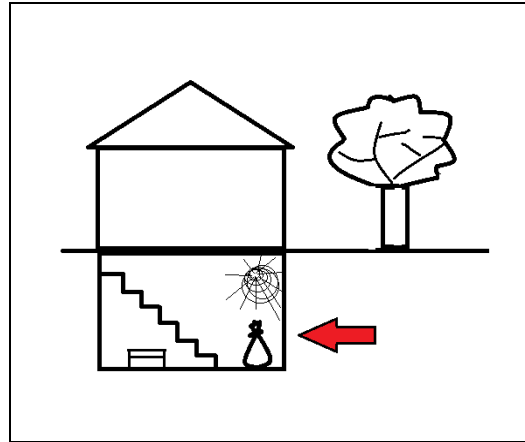

Katze

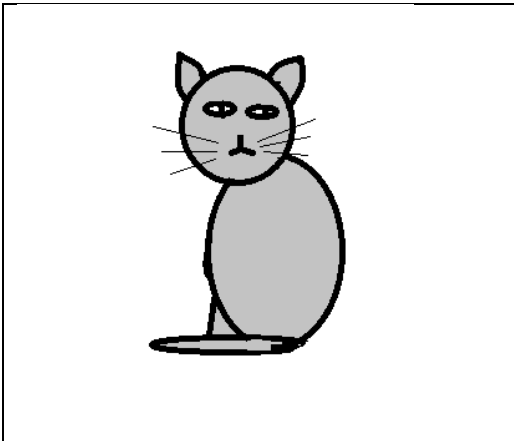

Tatze



Referenzkarten

/s/

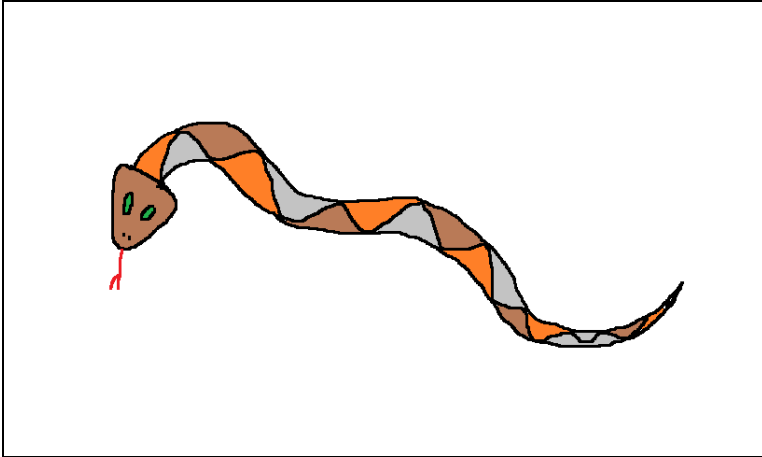

/f/

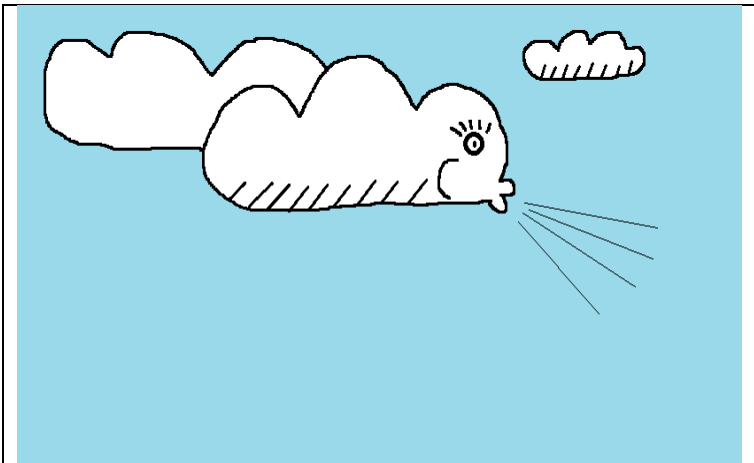

(c) Copyright Schulz-Kirchner Verlag, Idstein

/z/

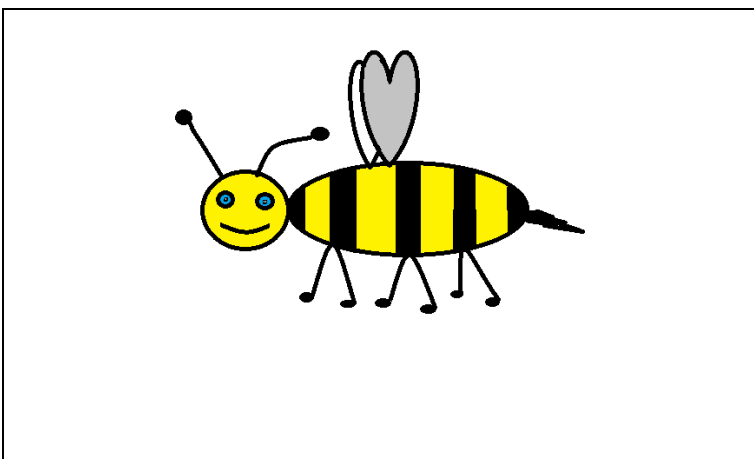

/sch/

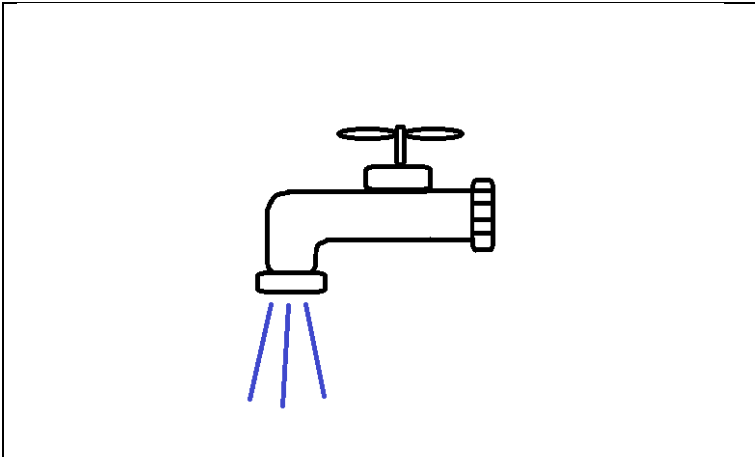
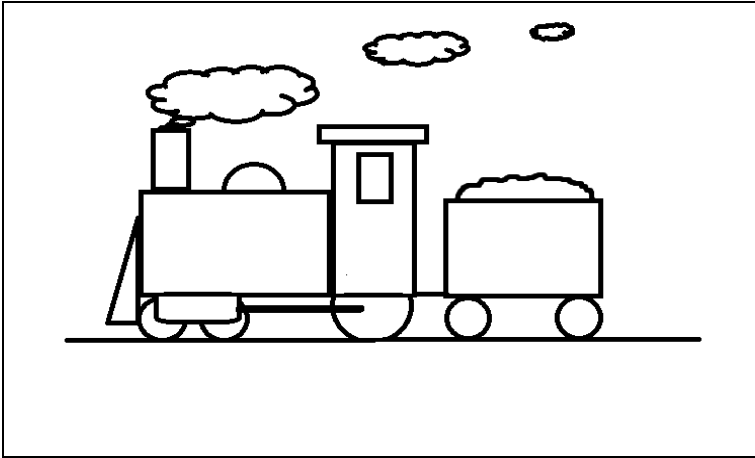

(c) Copyright Schulz-Kirchner Verlag, Idstein

/v/

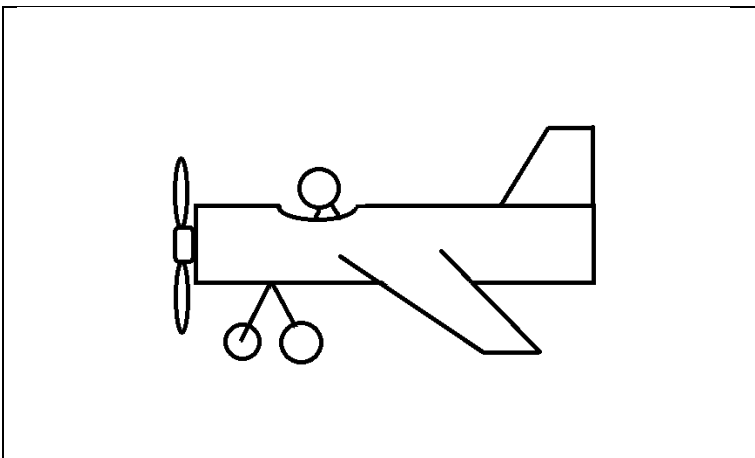

/ch1/



/ch2/

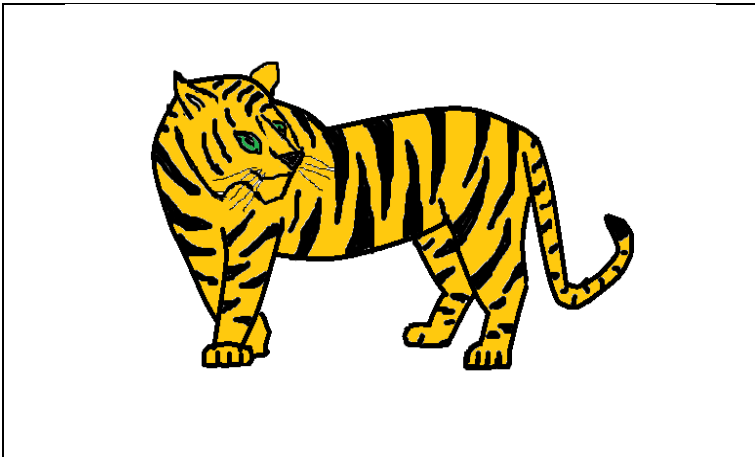

Liste: Auswahl von Neologismen zu Fallbeispiel 2 (P.O.P.T.)

/f/	fohl, fiem, nof, maff, flam, flun, fame, fulo, fomel, nanuf, manif, mefel, lufel, mafel, mafne, laffe, flinne, fleme
/v/	wom, wull, wamme, wele, willu, wulle, nuwe, neue, lawi, mawe, luwe
/s/	mes, moss, lus, nomis, lomas, mines, lösli, nieslim, lisme, nüsmе, lisse, mussel, lesse
/z/	sünn, sill, lase, mase, nüse, läse, sühle, suhme, salle, sillo, seime
sch	schum, schem, schöl, lusch, mosch, niesch, nalsch, mamsch, lenisch, lambusch, malisch, imschel, loschel, luschel, schniel, schlan, schman, schlaume, schlome, schnele
ch1	neich, nilch, lolch, mennich, menich, lemmich, lichme, neichel, lühnchen, nillchen
ch2	nuch, moch, luch, maloch, lemoich, melach, monoch, luche, muche, nuchme, lachme